

# CARGO TROLLEY WITH TURN TABLE

Instruction manual



**⚠ WARNING:**

Read the instruction manual carefully before using the appliance and follow all given instructions.

# **SAFETY INSTRUCTIONS**

---

**READ THESE INSTRUCTIONS CAREFULLY AND NOTE THE SAFETY INSTRUCTIONS AND WARNINGS. USE THE APPLIANCE CORRECTLY AND WITH CARE FOR THE PURPOSE FOR WHICH IT IS INTENDED. FAILURE TO DO SO MAY CAUSE DAMAGE TO PROPERTY AND/OR SERIOUS PERSONAL INJURY. KEEP THIS INSTRUCTION MANUAL SAFE FOR FUTURE USE.**

This appliance can be used by children aged from 8 years and above and persons with reduced physical, sensory or mental capabilities or lack of experience and knowledge if they have been given supervision or instruction concerning use of the appliance in a safe way and understand the hazards involved. Children shall not play with the appliance. Cleaning and user maintenance shall not be made by children without supervision.

**KEEP WORK AREA CLEAN.**

Cluttered areas and benches invite accidents.

**STORE IDLE APPLIANCES.**

When not in use, appliances should be stored in a dry, high or locked-up place, out of reach of children.

**DO NOT FORCE THE APPLIANCE.**

It will do the job better and safer at the capacity for which it was intended.

**USE THE RIGHT APPLIANCE.**

Do not force small tools or attachments to do the job of a heavy duty tool. Do not use tools for purposes not intended.

**KEEP GUARDS AND SAFETY DEVICES IN PLACE AND IN GOOD WORKING ORDER.**

Do not use the appliance without guards or safety devices, if such exist.

**DO NOT OVERREACH.**

Keep proper footing and balance at all times.

**MAINTAIN TOOLS AND APPLIANCES WITH CARE.**

Keep tools clean and in good condition for better and safer performance. Follow instructions for lubrication and changing accessories.

**ALWAYS STAY ALERT AND WATCH WHAT YOU ARE DOING.**

Use common sense when operating the appliance. Do not use the appliance while you are tired, sick or under the influence of alcohol, drugs, medication or other substances that could affect your ability to react.

**CHECK THE APPLIANCE FOR DAMAGES.**

If you notice any damages in the appliance, in its guards or other parts, do not use it until it has been repaired in an authorized service center. Check for alignment of moving parts, free running of moving parts, breakage of parts, mounting and any other conditions that may affect the appliance operation. Damaged parts should be properly repaired or replaced by an authorized service center unless otherwise indicated in this instruction manual.

**USE ONLY ORIGINAL SPARE PARTS AND ACCESSORIES.**

The use of any other spare parts or accessories than original parts may cause a risk of personal injury.

**REPAIRS SHOULD ONLY BE CARRIED OUT BY AN AUTHORIZED SERVICE CENTER USING ONLY ORIGINAL SPARE PARTS, OTHERWISE THIS MAY RESULT IN CONSIDERABLE DANGER TO THE USER.**

## SPECIFIC SAFETY INSTRUCTIONS

---

- Never exceed the maximum capacity of the appliance.
- Always use suitable equipment (e.g. a toe jack) for loading the appliance.
- While loading, ensure that the weight of the load is equally distributed and none of the trolleys is overloaded.
- Ensure that the load is not unbalanced on the trolleys and cannot decline, tip or fall.
- Never operate the appliance on the floor that is slanted, uneven or on different levels.
- Always ensure that the floor is clean and free from objects (e.g. stones) that could damage the wheels of the appliance or cause an abrupt stop, moving of the load or other dangerous situation.
- Never use the appliance for transporting people.
- Do not use the appliance if it is damaged.
- Do not move or transport loads that are unbalanced.
- Always wear protection shoes while lifting or transporting heavy loads.
- Do not put your hands or feet under the load after loading it on the trolleys.
- While transporting the load, always ensure that there is no one nearby who could be knocked down by the moving load. The extent of the danger zone depends on the load to be transported (e.g. the load height, width etc.).

**WARNING! The warnings and instructions given in this instruction manual cannot cover all possible conditions and situations that may occur on the worksite. It must be understood by the operator that common sense and caution are factors, which cannot be built into any product, but must be applied by the operator.**

## TECHNICAL DATA

---

Model	Capacity (lb.)	Length (in.)	Width (in.)	Height (in.)	N.W (lb.)
CRA-4	13,000	11-27/64	8-21/32	4-21/64	30
CRA-6	17,000	15-5/32	8-21/32	4-21/64	44
CRA-8	26,000	18-57/64	8-21/32	4-21/64	60
CRA-9	33,000	15-5/32	11-13/16	4-21/64	64
CRA-12	39,000	18-57/64	12-13/32	4-21/64	82

## MAINTENANCE

---

1. Inspect the trolley and the wheels regularly and before each use to ensure that they are in good operating condition.
2. Keep the wheels clean and remove all the metal pieces, screws, stones and other debris that have collected around them.
3. Lubricate the wheels to ensure that they move freely and effortlessly. This way, the loads are easier to transport.

**MODEL CRA-4**

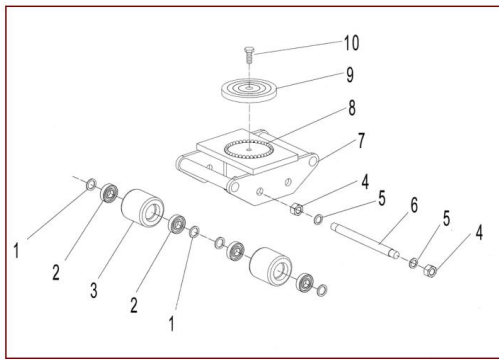

No.	Description	Quantity
1	Washer	8
2	Bearing	8
3	Wheel	4
4	Nut	4
5	Elastic Washer	4
6	Axle	2
7	Frame	1
8	Steel Ball	31
9	Turn Plate	1
10	Bolt	1

**MODEL CRA-6**

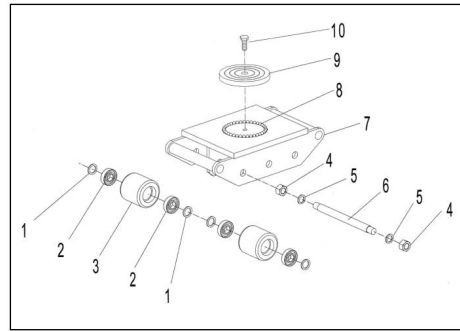

No.	Description	Quantity
1	Washer	12
2	Bearing	12
3	Wheel	6
4	Nut	6
5	Elastic Washer	6
6	Axle	3
7	Frame	1
8	Steel Ball	31
9	Turn Plate	1
10	Bolt	1

**MODEL CRA-8**

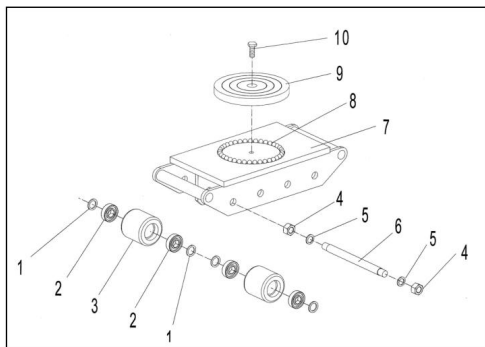

No.	Description	Quantity
1	Washer	16
2	Bearing	16
3	Wheel	8
4	Nut	8
5	Elastic Washer	8
6	Axle	4
7	Frame	1
8	Steel Ball	31
9	Turn Plate	1
10	Bolt	1

**MODEL CRA-9**

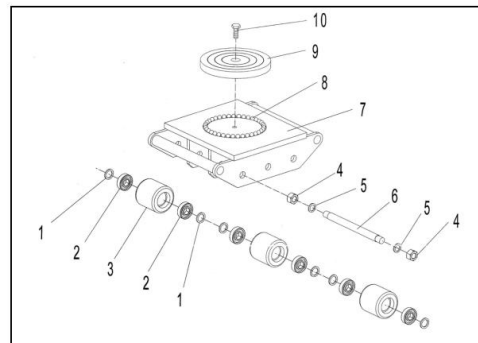

No.	Description	Quantity
1	Washer	18
2	Bearing	18
3	Wheel	9
4	Nut	6
5	Elastic Washer	6
6	Axle	3
7	Frame	1
8	Steel Ball	31
9	Turn Plate	1
10	Bolt	1

**MODEL CRA-12**

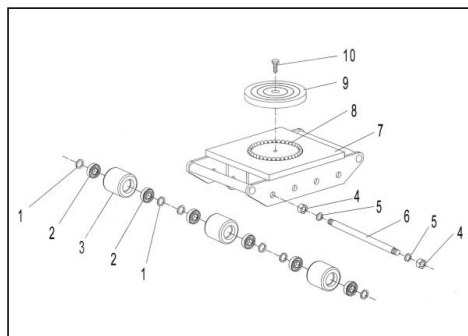

No.	Description	Quantity
1	Washer	24
2	Bearing	24
3	Wheel	12
4	Nut	8
5	Elastic Washer	8
6	Axle	4
7	Frame	1
8	Steel Ball	31
9	Turn Plate	1
10	Bolt	1